

Self-Organized Periodic Photonic Structure in a Nonchiral Liquid Crystal

L. Z. Ruan and J. R. Sambles

Thin Film Photonics Group, School of Physics, University of Exeter, Stocker Road, Exeter EX4 4QL, United Kingdom

I. W. Stewart

Department of Mathematics, University of Strathclyde, Livingstone Tower, 26 Richmond Street, Glasgow G1 1XH, United Kingdom

(Received 16 December 2002; published 15 July 2003)

A hybrid-aligned cell of the smectic *A* liquid material 8CB gives two stable director configurations, one of which is periodic and gives strong diffraction of light. This photonic lattice director profile arises from “frustration” caused by conflicting constraints imposed by the boundary conditions and the constant amplitude smectic density wave. A model is proposed which accords well with the experiment results, predicting correctly the dependence of the periodicity on the cell thickness and reproducing optical polarization microscopy results.

DOI: 10.1103/PhysRevLett.91.033901

PACS numbers: 42.70.Qs, 42.79.Dj, 64.70.Md

Frustration results from the competition between different influences on a physical system that favors incompatible ground states. It leads to the formation of a variety of complex ordered spatial structures. In this study frustration within a smectic *A* liquid crystal leads to a very well-ordered photonic lattice that gives strong optical diffraction.

There are many examples of frustration phenomena [1,2] to be found in nature. One of the classic simple examples is that of a constrained chiral liquid crystal. In chiral liquid crystals the competition between the favored twist state due to the chiral characteristics and the uniform state due to the applied electric or magnetic field or geometric constraints often causes the formation of periodic frustration structures [3]. However, there appears to be no mention of a frustration structure for the case of nonchiral liquid crystals even though there are many theoretical and experimental studies [4–8] concerning defect structures of smectic liquid crystals.

In this present study a thin layer of nonchiral liquid crystal 8CB is sandwiched in a hybrid-aligned cell, in which one surface is a rubbed polyimide layer, causing homogeneous alignment (director parallel to the surface) and the other surface is coated with lecithin to provide homeotropic alignment (director perpendicular to the surface). The cell structure is shown in Fig. 1. The cell is filled in the isotropic phase at an elevated temperature and then slowly cooled to room temperature. For different cells one of two different states is seen to form. One is an optically transparent state, while the other is a scattering state, which when viewed under the polarizing microscope is seen to comprise of a very regular, almost hexagonal, periodic pattern. This hexagonal structure also gives excellent optical diffraction of visible radiation.

For the transparent state the fully leaky guided mode technique [9] is used to characterize the director profile in the cell. For the scattering state, optical microscope images at different angular settings (Fig. 2) are recorded

using fixed crossed polarizers. In addition, the scattering cell is placed perpendicular to an incident laser beam of 632.8 nm radiation giving a hexagonal diffraction pattern (Fig. 2).

First, using multilayer optics theory, the guided mode data taken from a transparent cell are fitted and it is found that in most of the cell the director is parallel to the rubbing direction on the cell surface, only splaying strongly near the homeotropic surface. The director tilt profile is shown in Fig. 3. This result indicates that in this case the smectic layers, for most of the cell, are perpendicular to the cell surface (the smectic density wave is parallel to the cell walls). This preference for the planar state may be responsible for the formation of the transparent state, with a highly splayed, possibly defect-full region near the homeotropic wall. It may also be possible that this highly splayed region is actually held in the nematic state because the smectic state excludes this type of distortion. This would be analogous to the nematic state found to coexist with a smectic in a highly twisted homogeneously aligned smectic *A* cell [10].

The main focus of attention here is, however, on the scattering state. The microscope images (Fig. 2) show a

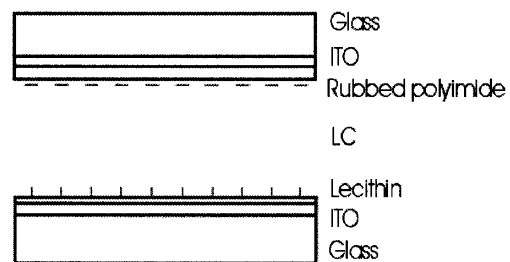

FIG. 1. Cell structure; short lines indicate the director alignment at the two surfaces. On the upper surface the director is aligned in the surface plane (homogeneous); on the lower surface it is aligned perpendicular to the surface plane (homeotropic).

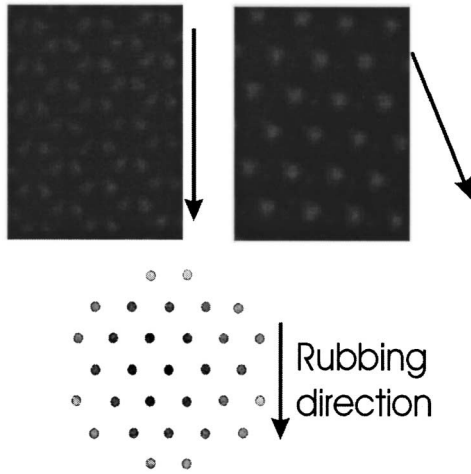

FIG. 2. Polarized optical microscopy of the frustration structure with crossed polarizers set horizontally and vertically and also the diffraction pattern. The rubbing direction is indicated by the arrows.

well-ordered structure, a “frustration” structure. This consists of a regular series of domains and defects. Since the liquid crystal, 8CB, is in a smectic phase at room temperature, this frustration is caused by competition between the smectic density wave and the hybrid-aligned surface alignment constraints. From these images the periodic structure appears in three directions, with 60° between them, one of these being perpendicular to the rubbing direction. The same period exists in all three directions with the structure also having mirror symmetry about the rubbing direction. This mirror symmetry, which is only about the rubbing direction, reveals that this structure is not hexagonally symmetric, even though the optical diffraction indicates this higher symmetry.

From this diffraction it is simple to find the repeat period of the structure, which is found to be close to the cell thickness (Fig. 4) of several micrometers. For thicker cells, above about $10 \mu\text{m}$, this frustration structure does not form. Additionally, under the application of a low electric field (about $1.5 \text{ V}_{\text{rms}}/\mu\text{m}$) the periodic pattern remains stable with no change in period. Increasing the

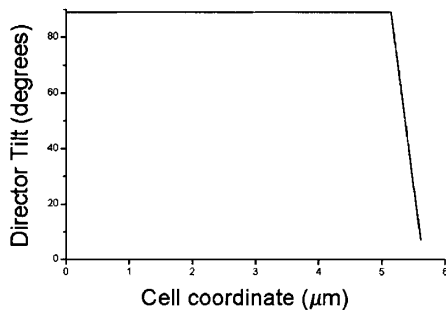

FIG. 3. Simple fitted director profile in a transparent cell.

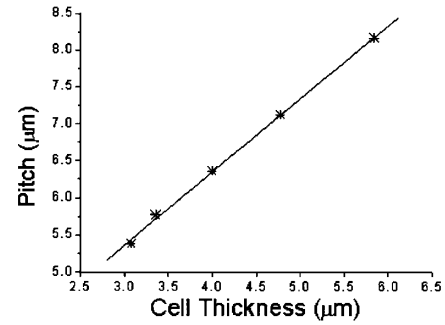

FIG. 4. Thickness dependence of the structure period.

files above this value destroys the ordered structure, which does not recover on removal of the field. Further, the periodic structure is also destroyed by repeatedly cooling and heating the cell between the isotropic state and room temperature.

By analyzing the images obtained from the microscope, a layer model may be proposed for this smectic A cell. The proposed structure, viewed from the top surface, which has the homogeneous surface treatment, is shown in Fig. 5. There is mirror symmetry about the rubbing direction. The partial circles in Fig. 5 represent the smectic layers, which are biased to align perpendicular to the rubbing direction simply because the director, which is perpendicular to the smectic layers, prefers to align along the rubbing direction. The basic unit for this structure is a diamond. Its symmetry axis is along the rubbing direction (shown in the inset in Fig. 5). The diagonal of the diamond, perpendicular to the rubbing direction, is the pitch “ p ” of the structure, and half of the pitch is the maximum radius “ a ” of the cylindrically aligned smectic layers. There are singularities at the apexes of the diamond and line defects on the sides of the diamond.

How does the smectic density wave vector (layer) change from the top surface of the cell, which favors homogeneous alignment, to the bottom surface, which favors homeotropic alignment? Consider the smectic layers as parts of cylinders in the top of the cell joining

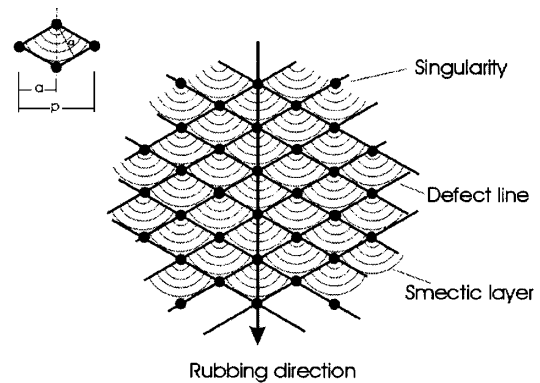

FIG. 5. Proposed smectic layer structure in a scattering cell.

parts of hemispheres near the bottom. [They cannot simply be parts of hemispheres because the experimental data show that the cell thickness is larger than the half-pitch a (see Fig. 4).] In this way, the director in the cell aligns parallel to the plane of the cell at the top and mostly perpendicular to the surface of the cell on the bottom (see Fig. 6). Actually, the point defects in Fig. 5 become vertical line defects in this structure.

From energy considerations the relationship between the size a of the constituent unit and the cell thickness d may be found. In the proposed model the energy for the cylindrical part is

$$\begin{aligned} w_c &= \frac{1}{2}K \int_{V_c} (\nabla \cdot \vec{n})^2 r dr d\phi dz, \\ &= \frac{1}{2}K \int_a^d dz \int_0^{2\pi/3} d\phi \int_{r_0}^a \frac{1}{r} dr \\ &= \frac{1}{3}K\pi(d-a) \ln\left(\frac{a}{r_0}\right), \end{aligned} \quad (1)$$

where V_c is the volume of the cylindrical part of the unit, K is the usual splay elastic constant, r_0 is a cutoff radius for the inner core around the axis of the cylinder, and $\vec{n} = \vec{r}$ is the director in cylindrical coordinates (here $\nabla \cdot \vec{n} = 1/r^2$). The energy for the hemispherical part is

$$\begin{aligned} w_s &= \frac{1}{2}K \int_{V_s} (\nabla \cdot \vec{n})^2 r^2 \sin\theta dr d\phi d\theta \\ &= \frac{1}{2}K \int_0^{2\pi/3} d\phi \int_0^{\pi/2} \sin\theta d\theta \int_0^a 4dr = \frac{4}{3}K\pi a, \end{aligned} \quad (2)$$

where V_s is the volume of the hemispherical part of the unit cell and $\vec{n} = \vec{r}$ is the director in spherical coordinates (here $\nabla \cdot \vec{n} = 4/r^2$). It is then supposed that the bulk cylindrical and hemispherical contributions are energetically the same, away from defects. In addition, there is a substantial contribution from defect energies as well as surface terms. Considering all of these effective factors the following equilibrium condition is suggested:

$$w_c = B' + C'w_s, \quad (3)$$

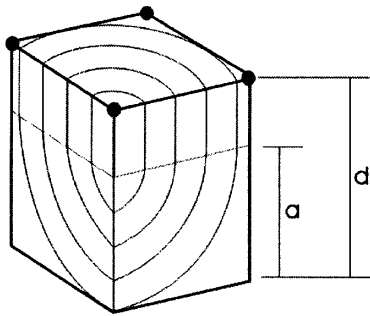

FIG. 6. The layer structure of a unit cell in three dimensions. Note that the concentric part cylinders in the upper half of the cell become concentric parts of spheres in the lower half.

where B' arises as a defect energy and C' is associated with the difference of the anchoring energies between the top and bottom surfaces. From Eqs. (1)–(3), with $a = p/2$, we have

$$d = \frac{3B'}{K\pi \ln(p/2r_0)} + \frac{1}{2}p \left(1 + \frac{4C'}{\ln(p/2r_0)}\right). \quad (4)$$

For p ranging from 5 to 8 μm , as in the data, and $r_0 = 5$ nm, the value of $\ln(p/2r_0)$ varies little, from 6.21 to 6.68, and d is therefore approximately linear in p . This leads to a relation of the form

$$d = B + Cp, \quad (5)$$

where B and C are constants. This linear relationship between the cell thickness d and the pitch p agrees well with the experimental data shown in Fig. 4. The solid line fit (see Fig. 4) of Eq. (5) to the data gives $B = -2.42$, $C = 1.01$. From these values a little more information may be found for this cell. First, because the constant B is negative, the constant B' in Eq. (3) is also negative. This means that the defect energy in the cylindrical part is larger than that in the hemispherical part. Second, the value obtained from C for C' of 1.61 indicates that the homeotropic anchoring is stronger than the homogeneous anchoring.

This proposed structure may also be used to explain the images recorded under the polarizing microscope. When the polarizer is set parallel to the rubbing direction, the image shown in the top left of Fig. 2 is obtained which corresponds well to the proposed extinctions from the suggested director profile indicated on the left side of Fig. 7. As the polarizer is twisted a certain angle from the rubbing direction the image, for example, shown on

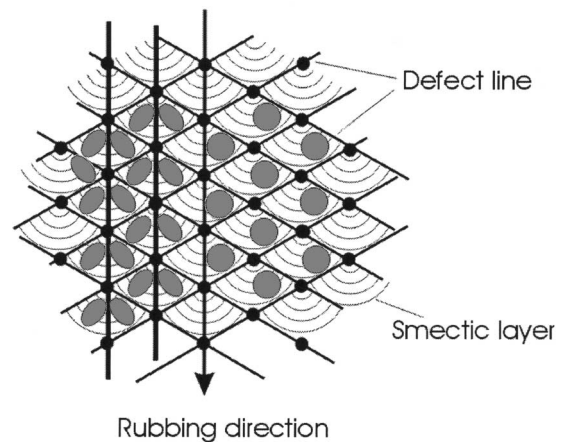

FIG. 7. A comparison of the experimental images of Fig. 2 and the supposed model. The left-hand part shows the bright transmission for the directors at 45° to the polarizers when one polarizer is along the rubbing direction. The right-hand part shows the effect of rotating the two polarizers by 22.5° .

the top right of Fig. 2, also agrees well with the proposed extinctions shown on the right side of Fig. 7.

A brief explanation for this frustration structure may be suggested. Since the liquid crystal 8CB is in the smectic *A* phase at room temperature, the two conflicting surface boundary conditions inhibit the formation of a uniform state. The perpendicular smectic layers, which try to form near the homogeneously aligning surface, are forced to bend close to the homeotropic-aligning surface. This situation attempts to resolve itself by imposing a decrease in the amplitude of the density wave (smectic layer spacing), which is forbidden [10], and so the layers in the homogeneously aligned region try to dilate to compensate. It is this dilation [11] that causes the curvature of the layers. The system then spontaneously produces the ordered array of defects discussed above. It should be remarked that line defects in the bulk of thin cells are not uncommon; in this example it is anticipated that there are line defects around the central cores of cylinders. It is known [11] that parabolic line defects, central to the construction of parabolic cyclides, can occur in the bulk of thin samples of non-hybrid-aligned cells of smectics.

In conclusion, using a hybrid-aligned cell a novel frustration structure has been found in a nonchiral liquid crystal. This comprises a regular series of cylindrical-spherical domains and defects which results in a very well-ordered photonic crystal. This frustration structure

is formed through the conflicting requirements of the surface constraints imposed on the constant amplitude smectic density wave (layer thickness). The pitch of the lattice formed is controlled by the cell thickness.

The authors are grateful for the support of the Engineering and Physical Sciences Council.

-
- [1] B. Gu, L. Chakraborty, and H. Yin, *Z. Phys. B* **12**, 6487 (2000).
 - [2] P.M. Chaikin and T.C. Lubensky, *Principles of Condensed Matter Physics* (Cambridge University Press, Cambridge, 1995), Sec. 9.6.
 - [3] R. D. Kamien and J.V. Selinger, *J. Phys. Condens. Matter* **13**, R1 (2001).
 - [4] P.G. de Gennes and J. Prost, *The Physics of Liquid Crystals* (Clarendon, Oxford, 1993).
 - [5] R. Ribotta and G. Durand, *J. Phys. (Paris)* **38**, 179 (1977).
 - [6] M. Kléman, *J. Phys. (Paris)* **38**, 1511 (1977).
 - [7] I.W. Stewart, *Liq. Cryst.* **15**, 859 (1993).
 - [8] I.W. Stewart and G.J. Barclay, *Mol. Cryst. Liq. Cryst.* **328**, 505 (1999).
 - [9] Fuzi Yang and J. R. Sambles, *J. Opt. Soc. Am. B* **16**, 488 (1999).
 - [10] L. Z. Ruan, M. A. Osipov, and J. R. Sambles, *Phys. Rev. Lett.* **86**, 4548 (2001).
 - [11] Ch. S. Rosenblatt, R. Pindak, N. A. Clark, and R. B. Meyer, *J. Phys. (Paris)* **38**, 1105 (1977).