

**A**

Chant des femmes: "Nenni de nenni nenni"

"Has nenni nenni"

25

7

N



"gerçek canlara"

Chant des hommes: "Bizden selam olsun"

5

5

5

5

6

6

6

6

6

Text des reprises "gerçek canlara / Vücden serrini / yuganlar gelsin / yuganlar gelsin / Yedi kat göklerin / yedi kat yerin / yedi kat yerin / Kudret binası--nı"

"kuranlar gelsin"

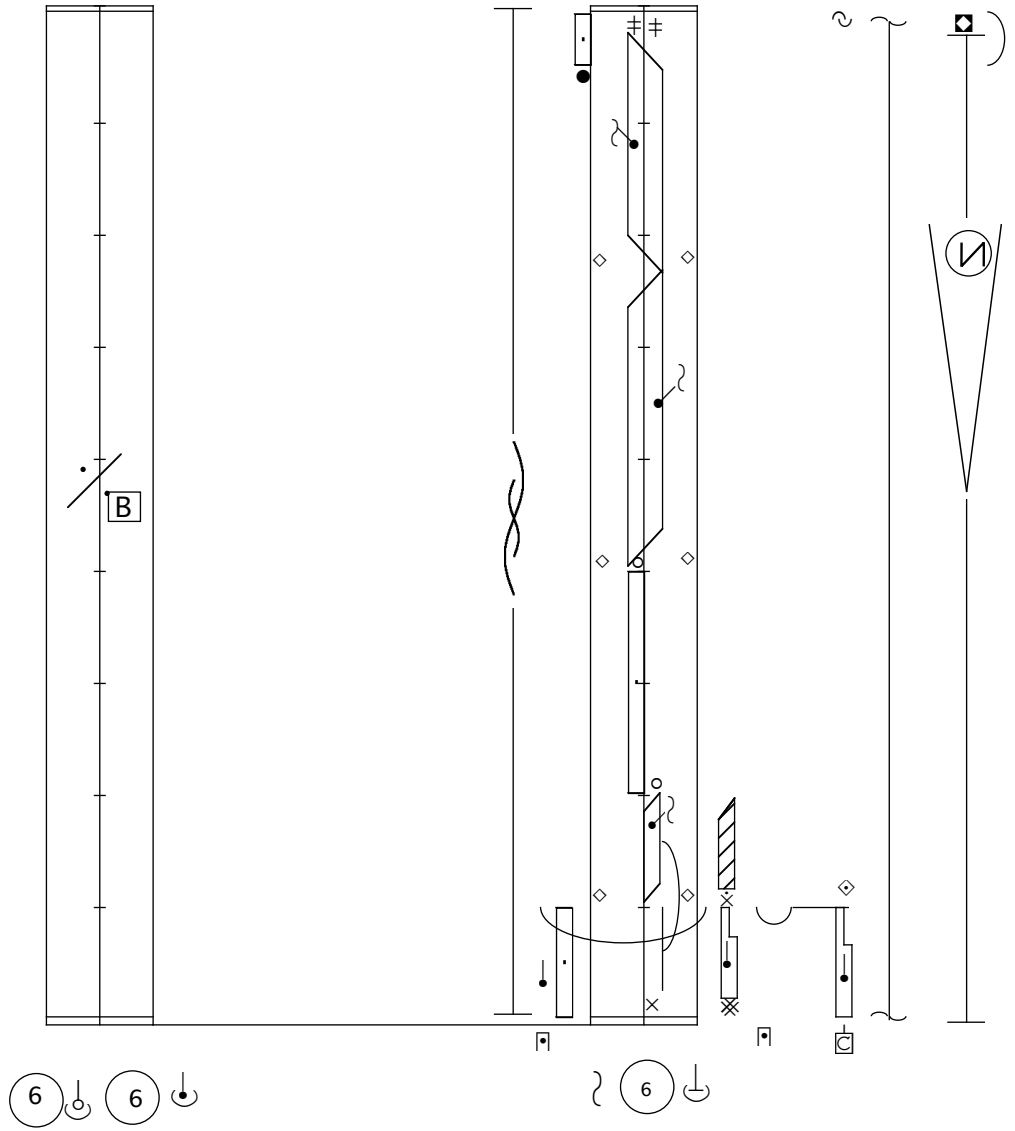

C

Chant des femmes: "Nenni de nenni nenni"

"Has nenni nenni"

6 6

Reprise des hommes: "Nenni de nenni  
nenni / Has nenni nenni / Dost nenni  
nenni"

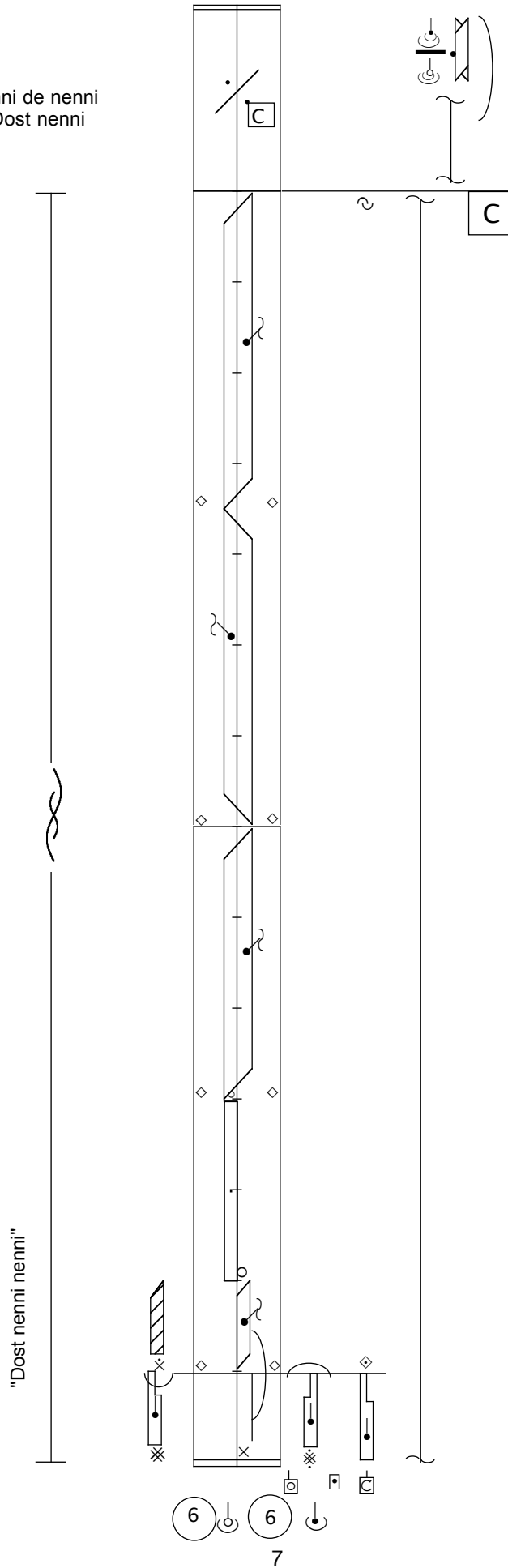

"Bir kolay istir"

Chant des hommes: "Sofu dedikleri"

4

4

6

6

II

Text des reprises: "bir kolay istir / Erenler gördüğü / bir engin düstür / bir engin düstür / Eti yok kanı yok / bir uçan kustur"



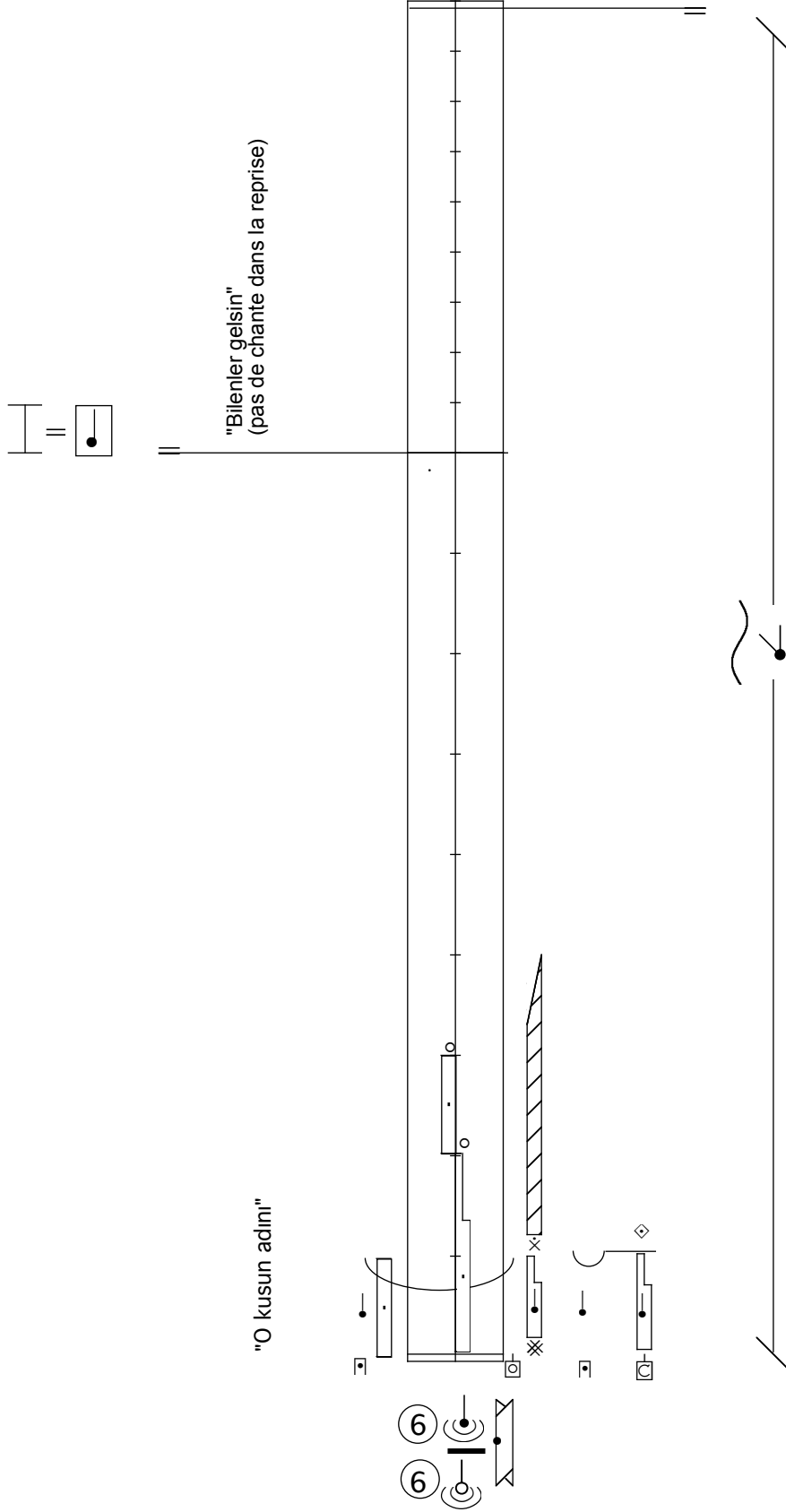

Reprise des hommes "Nenni de nenni nenni / Has nenni nenni / Dost nenni nenni"

"Nenni de nenni nenni"

"Has nenni nenni"  
 (+ 2eme reprise: "Dost nenni nenni")  
 ( pas de chante dans la 3eme reprise)

3

3

E

E

The diagram shows a musical score for a dance. It features a central vertical staff with rhythmic markings. To the left, there are boxes labeled 'E' and a bracketed section. Below the staff, there are various musical notations including notes, rests, and symbols like 'x' and 'o'. At the bottom left, there are two circled '6' symbols with notes. To the right, there is a long vertical line with a wavy line and a dot, possibly representing a dance movement or a specific rhythm.

Chant solo du zakır: "Eti yok kanı yok / Bir uçan kustur / O kusun adını / Bilenler gelsin / Bilenler gelsin"

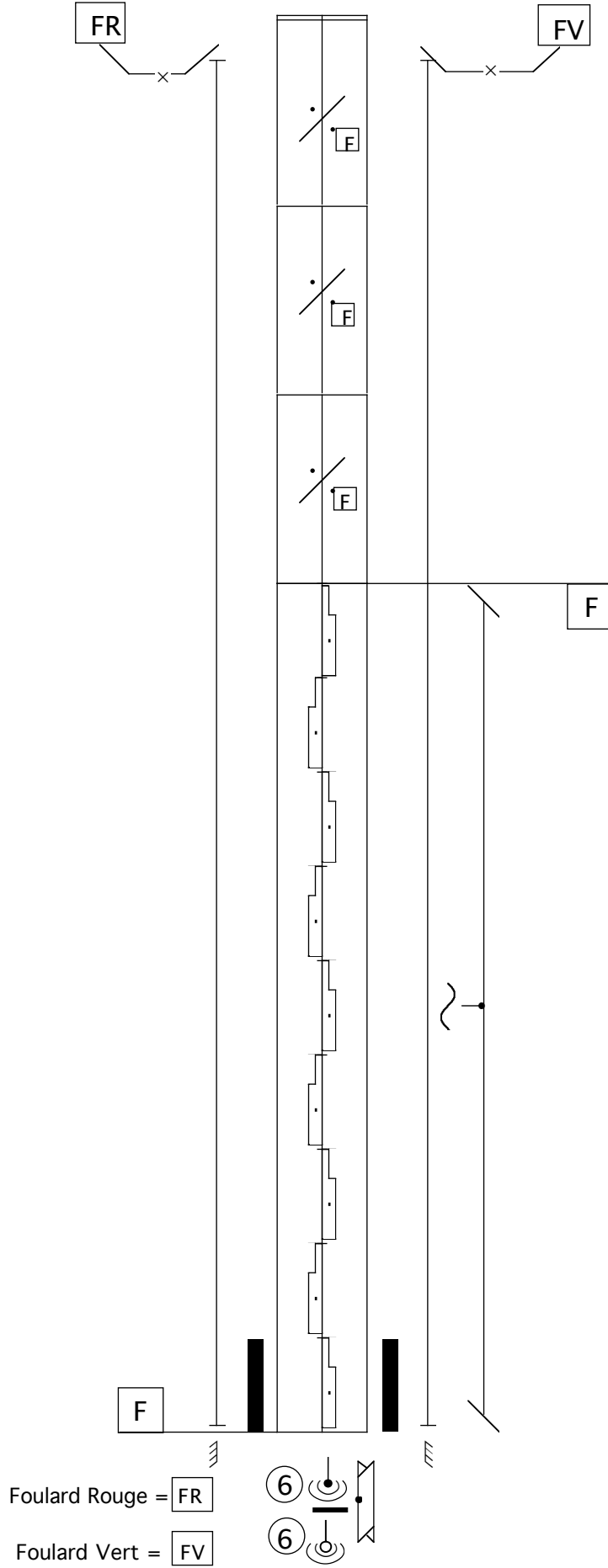

Chante des hommes et des femmes:  
"Bu yolun erkanın bilenler gelsin"

Chante des hommes et des femmes:  
"Kim sürdü kuyuda kırk arsin yolu"

Chante des hommes et femmes:  
"Altından çakılmış düldülün nalı"

Chantè des hommes et des femmes:  
"Pirimi sorarsan Ali'dir Ali"

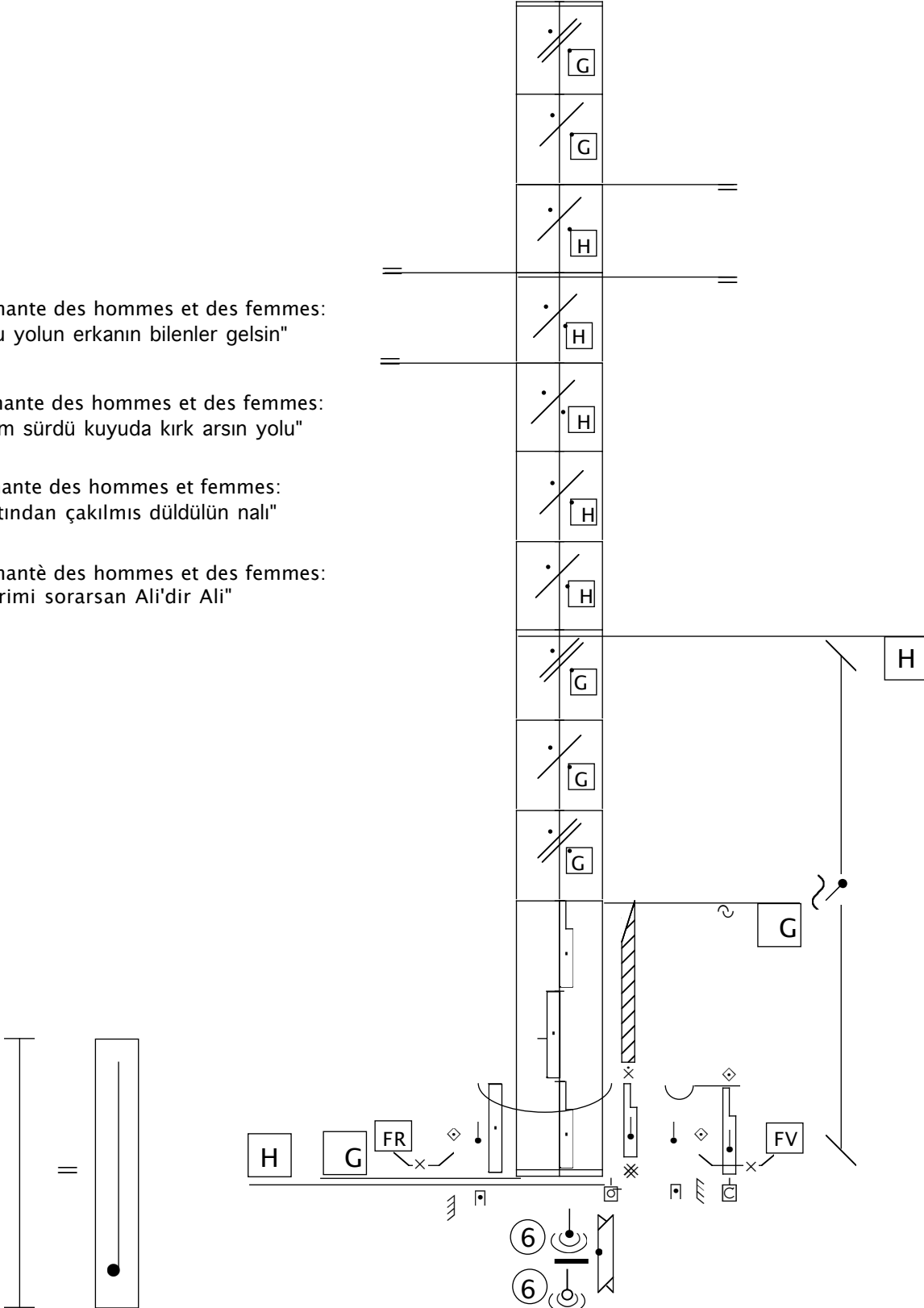

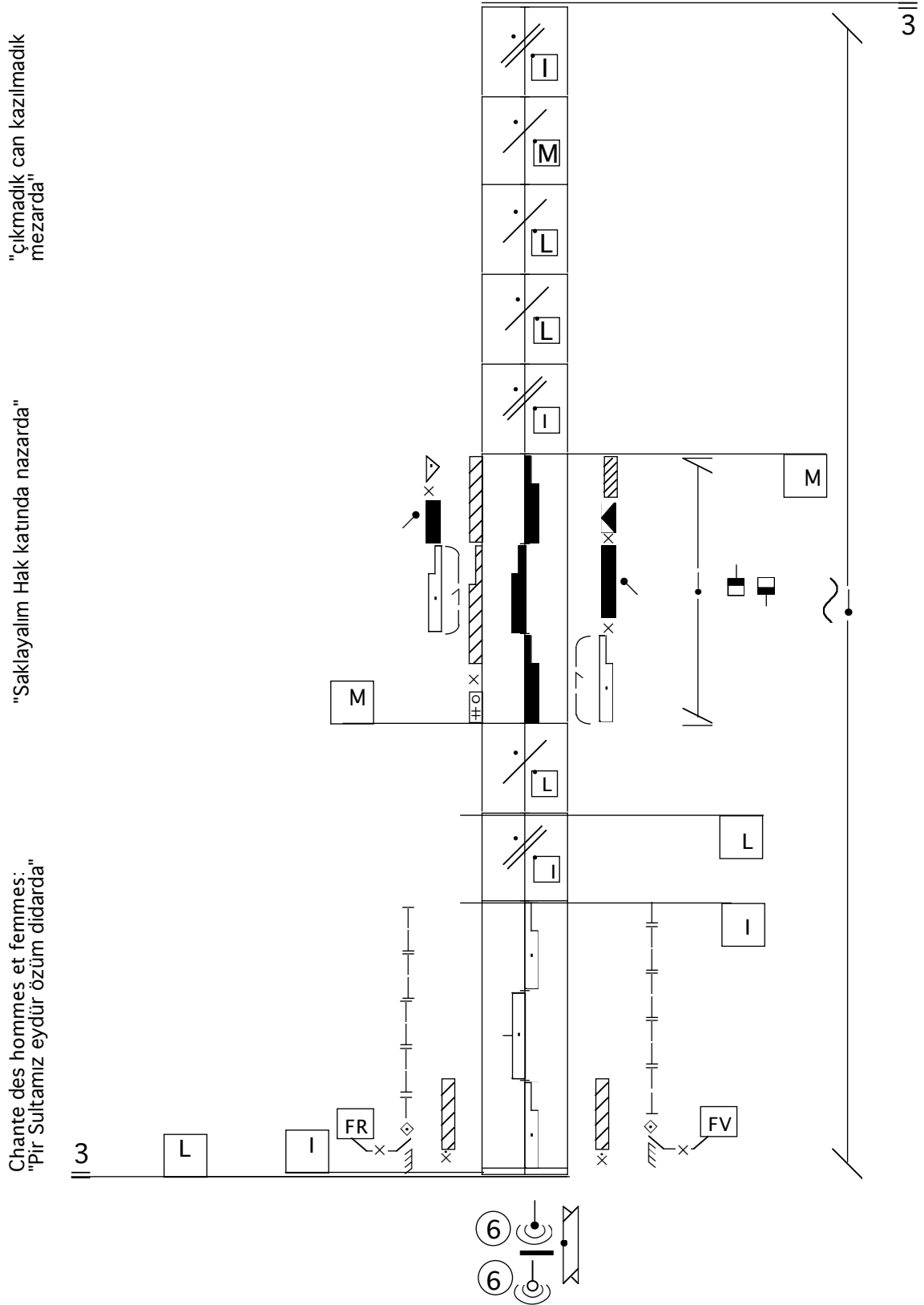

Text des reprises: "O canın namazın kılanlar gelsin / O canın namazın kılanlar gelsin / Pir Sultanım Eydür özüm didarda" et "Saklayalım Hak katında nazarda / Çıkmadık can kazılmadık mezarda/ O canın namazın kılanlar gelsin".

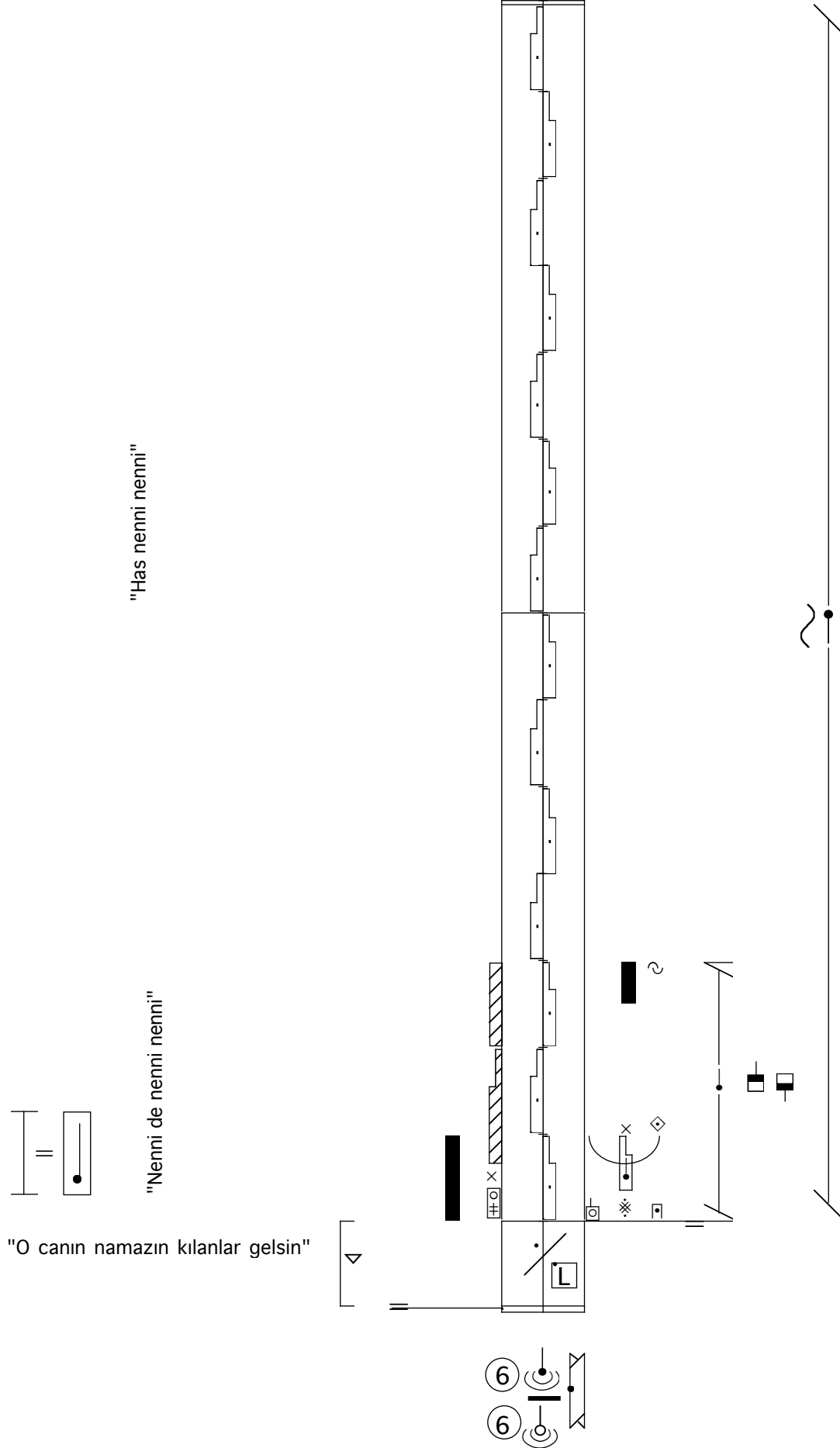

"Dost nenni nenni"

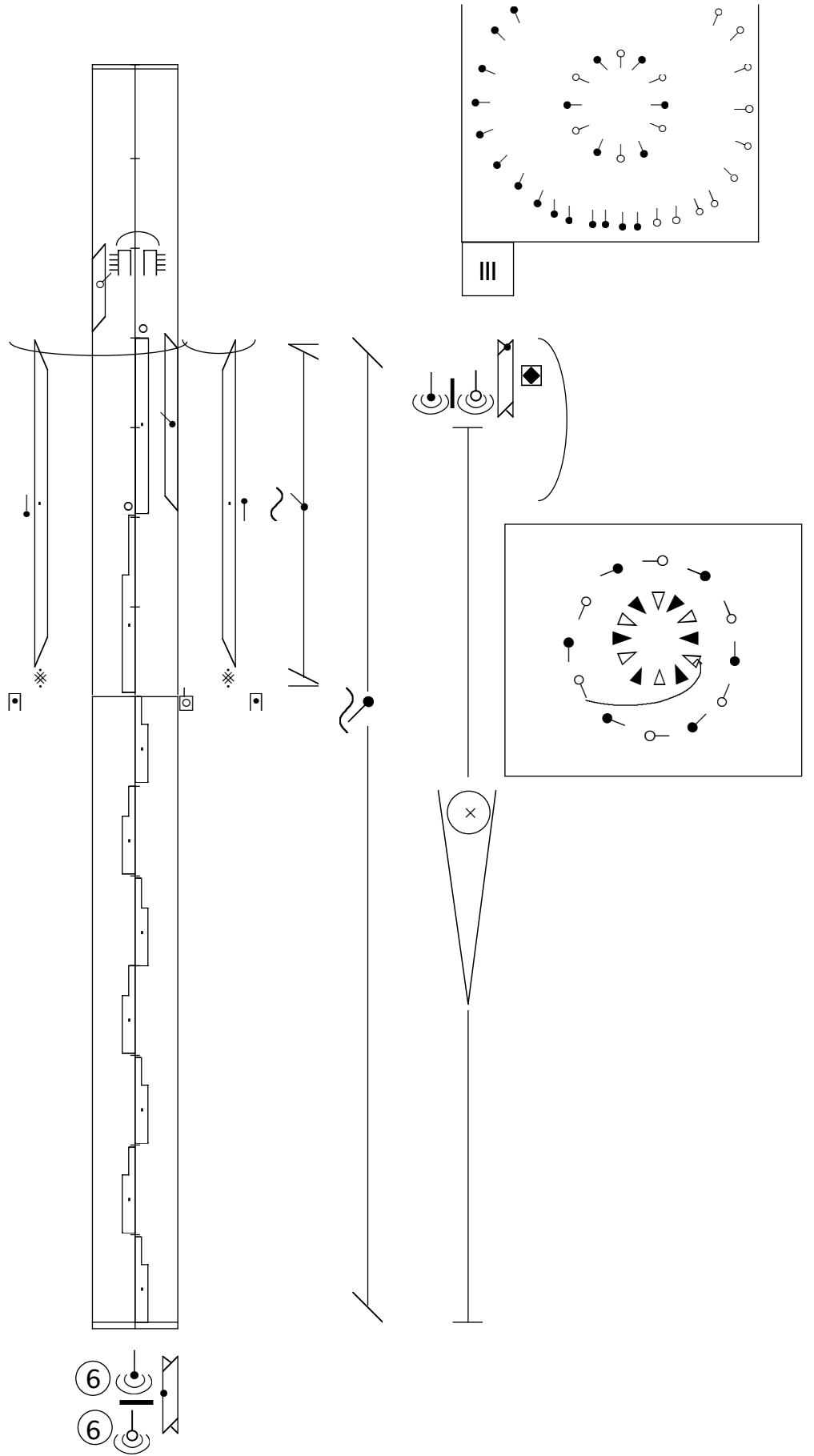

"Has nenni nenni"

"Nenni de nenni nenni"

