

Designing an "Outphaser"

by David Gibson

A precision "outphaser" or "Hilbert Transformer" is described, for use in an SSB radio. The design is conceptually easy, using simple first-order all-pass filters. Design parameters, component values and a circuit diagram are given.

Introduction

An "outphaser" or "Hilbert Transformer"¹ is a device for shifting the phase of a signal by 90° without changing its amplitude, regardless of the frequency. One of the methods of SSB modulation and demodulation uses an outphaser to achieve cancellation of the unwanted sideband.

It can be proved that a "perfect" outphaser, which works at all frequencies, is physically impossible to construct. An integrator or differentiator achieves a 90° phase shift, but has a varying gain with frequency. For 90° phase shift *and* constant gain we require a more complex network. And since a perfect outphaser is impossible, the network must be a compromise.

Many designs of outphaser have appeared over the years. However, an adequate description of how they work is rarely seen. My proposed cave radio receiver design might require an accurate out-phaser, and it was with this in mind that I wrote a description of the device in previous articles. (Gibson, 1992, 1994).

There is sufficient information in those articles to design an outphaser from scratch, if one is prepared to wade through the maths. However, I have been asked to "come up with the component values", so this article does just that.

To avoid repeating myself too much, this article does not explain the "how and why" using an outphaser. It assumes that the previous two episodes have been read. I have taken the opportunity to update my calculations of the parameters.

First-Order Network

A simple RC low-pass filter has a phase shift of -45° at its -3dB frequency (ω_0). However, by driving the bottom of the network with an inverted signal (Gibson 1992, Fig 3a) we can get a 90° shift at ω_0 . Driving the filter like this results in an all-pass response where the phase-shift varies with frequency, but the gain remains constant. The phase shift is ϕ defined from

$$\tan \frac{1}{2} \phi = -\frac{\omega}{\omega_0} \quad (1)$$

so if we move by, say, $\pm 5\%$ of the centre frequency (a frequency range of 1.1 to 1) the phase shift will be about $\pm 3^\circ$ variation from -90°. As John Hey has pointed out², this is adequate for use at r.f. For example, with a 6MHz centre frequency, we could maintain the phase shift to $\pm 3^\circ$ over a bandwidth of 600kHz.

For some applications it would be possible to use the outphaser at a sufficiently high r.f. or i.f. that a simple first-order network would do. However, if we do not want to use an i.f. (even 30kHz would do!) then the outphaser must work at baseband, where a simple RC filter is inadequate.

Multi-section Filters

We achieve the 90° phase shift over an audio range of perhaps 20:1 by looking at the *difference* between the outputs from two filter networks (Gibson, 1992). With a single pair of first-order sections the phase difference can be tweaked to $90^\circ \pm 3^\circ$ over a range of around 2.5 to 1. This is still not large enough for audio work, so we need to use higher-order filters.

A common configuration is to use passive second-order filters. It is very rare to see any analysis of such a circuit; the component values being radio "folklore". An analysis by Walters (1986) did not really achieve the aim of making the filter easier to design. My approach is to use active first-order filters³ because they are conceptually easier to analyse, and op-amps are cheap.

In case you think that we do not *need* to analyse a circuit which is already presented, let me point out that I have analysed several outphaser circuits which did not have the performance they claimed.

Required Accuracy

The phase shift needs to be 90° and the amplitude difference should be zero. If this is not so then we will not get perfect attenuation in the unwanted sideband. An expression for the error was derived in

Gibson, 1992. If the phase error⁴ between the two channels is ϕ (degrees) and the ratio of the amplitudes is $1 + 2\alpha$ (with $\alpha \ll 1$ and $\phi\pi/360 \ll 1$) then the attenuation of the unwanted sideband is

$$\left(\frac{\pi}{360}\right)^2 \phi^2 + \alpha^2 \quad (2)$$

For example, if we can maintain the phase error (ϕ) to 8°, and the amplitude (α) to $\pm 7\%$ then both errors will contribute equally to the "leak-through"; and the unwanted sideband will be at a power level of 1/102 of the wanted sideband, or -20dB[W]. This is acceptable for transmission because we do not have any channel restrictions and this level of accuracy would not waste any power. For reception, however, an attenuation of -20dB in the unwanted sideband might not be adequate unless we have additional r.f. selectivity.

We may be able to trim out the gain error⁵ but coping with phase errors is not so easy. Even with 1% capacitors and resistors there is scope for some error to creep in. I will discuss the magnitude of the errors later, but with $\alpha = 0$ and $\phi = 2^\circ$ (say) we will have a power attenuation of 35dB which is better. At 1° we will have -41dB, but $\alpha = \pm 1\%$ would bring this down to -38dB.

Difference of One Pair of 2nd-Order Filters

An example in Gibson (1992) demonstrated this, and showed that with a pair of second-order all-pass filters we could achieve $90^\circ \pm 5^\circ$ over a frequency range of 25:1, e.g. from 200Hz to 5kHz. This was not particularly good, but served to demonstrate the principles of a baseband outphaser.

Difference of Two Pairs of 1st-Order Filters

Using a single pair of second-order filters is similar to using *two* pairs of first-order filters. There are several ways in which a first-order filter can be constructed. The most suitable one for use at a.f., with op-amps, is shown in Figure 1. The centre frequency is $f_c = 1/RC$ and the gain is set to unity by r_1, r_2 .

¹ i.e. a device which implements a mathematical transform known as the Hilbert Transform.

² Personal correspondence with the author

³ In his new cave radio design, John Hey uses second-order filters (Hey, 1995). His circuit is analysed in Appendix 1. Unlike some offerings, John's *does* give an accurate 90° shift. It is similar in performance to one of the first-order examples I will give later.

⁴ Here I have used ϕ to mean the total phase error. Previously I used $\phi = \phi/2$. You need to be very careful which you use, because there is a substantial difference in the result.

⁵ This depends on the design - if the gain error varies with frequency then it cannot be trimmed.

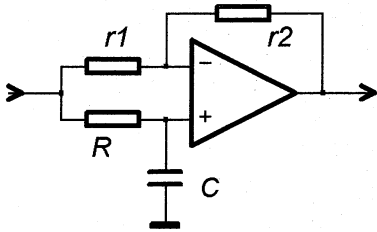

Figure 1 : First-order All-pass Filter

There is a minor disadvantage in that a first-order design uses more op-amps and a few more resistors than a similar second-order design. But a first-order network has several advantages over the more complex second order network, namely

- It has unity gain, with $r_1 = r_2$ so there is no need to set an accurate non-unity gain.
- It only has a single C so this can be chosen for cost and availability. We don't need to choose two accurately matched C s in E24 values.
- With C fixed, the only component which affects the centre frequency is R .
- The gain can easily be trimmed to unity by adjusting r_1 and r_2 .

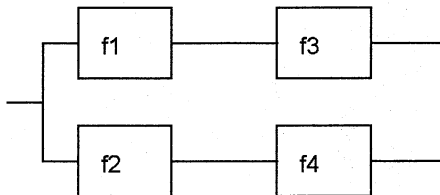

Figure 2 : Two pairs of 1st order filters

The difference between the two outputs approximates to a 90° phase shift.

Figure 2 shows how the outphaser is configured⁶. There are four first-order all-pass filters with centre frequencies f_1, f_2, f_3 and f_4 . These are arranged in two paths, and the wanted signal is the difference between the two. If we used only the f_1/f_2 pair the phase difference would be the left hand "hump" in Fig. 3. Using only the f_3/f_4 pair would give rise to the right-hand curve. The overall phase difference is found by adding the responses to give the third curve on the graph⁷.

To describe the filter I use two terms. The *span* is the ratio of the centre frequencies of the two filters comprising a "hump", as drawn in Figure 3. The *spread* is the ratio of the centres of the humps themselves.

⁶ This design, using two pairs of first order sections, wasn't discussed in the earlier articles.

⁷ We can note that finding a flat-top response in the phase domain is similar to the more conventional problem of finding a flat-top in the amplitude domain. Techniques for analysing ripple and for the combination of tuned-circuits to give flat-top responses have been well studied.

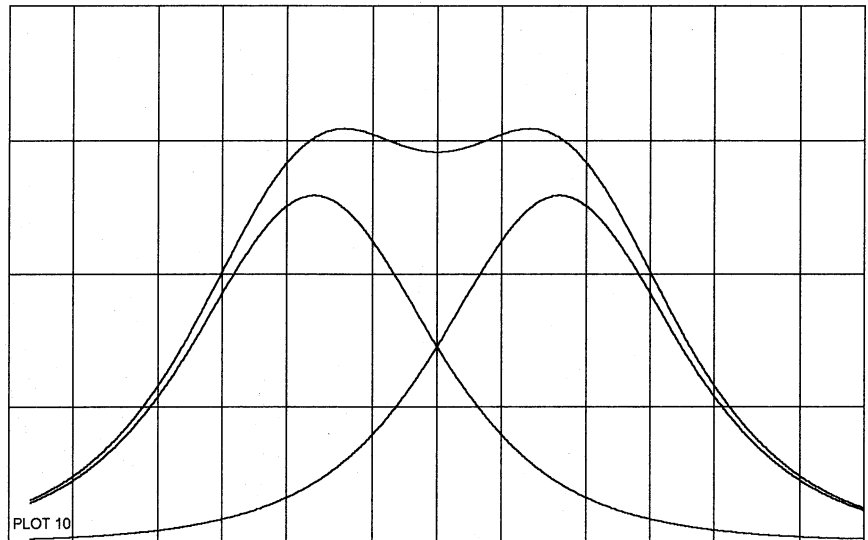

Figure 3 : Difference of two pairs of first-order sections, example 1
Axes: X: frequency (log scale 1-2-5), centre 1000Hz. Y: phase shift (30° intervals), centre 60°.

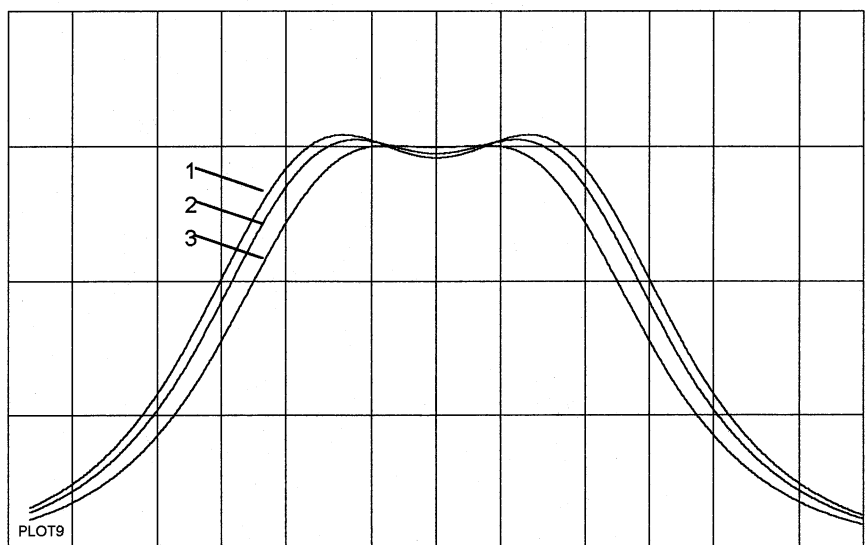

Figure 4 : Difference of two pairs of first-order sections, examples 1-3
Axes: X: frequency (log scale 1-2-5), centre 1000Hz. Y: phase shift (30° intervals), centre 60°.

I used a small BASIC program to investigate the filters by "trial and error". An algebraic solution is possible, but it is very intricate⁸.

Example 1

The filter in Figure 3 is centred around 1000Hz and the *spread* is 14. Thus the two humps must be at $f_{12} = 267\text{Hz}$ and $f_{34} = 3742\text{Hz}$, so that their ratio is 14:1, and the geometric mean, $\sqrt{(f_{12}f_{34})}$, is 1000Hz. The individual *spans* are both 4.36 so, similarly, we can derive

$$f_1 = 128.0\text{Hz} \quad f_3 = 1792\text{Hz}$$

$$f_2 = 558.1\text{Hz} \quad f_4 = 7813\text{Hz}$$

where $\sqrt{(f_1f_3)} = 267\text{Hz}$, $f_3/f_1 = 4.36$, and so on.

The phase shift at the centre frequency of 1000Hz is 87.48°, i.e. 2.52° below 90°. The peaks are at 92.66°. The response dips to 87° at 216Hz and 4620Hz. This could be

⁸ Contact the author if you are interested in an algebraic analysis currently being prepared.

loosely called the *bandwidth* because of the similarity to the useful response of a filter in the amplitude domain.

Examples 2 and 3

Using the BASIC program it is easy to see what happens as we reduce the spread. To maintain the 90° phase shift we need to increase the span. Figure 4 shows the effect of reducing the spread to 12 (Ex. 2) and to 9 (Ex. 3). The results are summarised in Table 1, later in the text.

The "phase ripple" listed in the table refers to the deviations from 90° of the turning points of the graphs. Notice that in Example 3 it is extremely low, almost within 1/4°; but the "bandwidth" is limited.

Example 2a

Of the above two examples, let us suppose that Example 2 looks like a suitable filter to build. The procedure is as follows. Firstly we note that all the examples used a centre frequency of 1000Hz. The individual sections of Ex. 2 have centre frequencies of

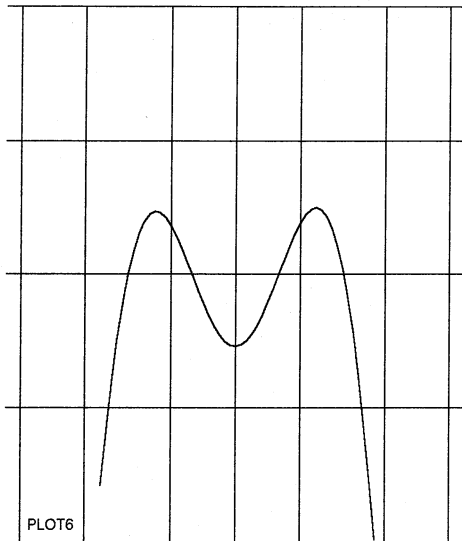

Figure 5 : Difference of two pairs of first-order sections, magnified central portion of response, component values from Example 2a
 Axes: X: frequency (log scale 1-2-5), centre 1000Hz. Y: phase shift (3° intervals), centre 90°.

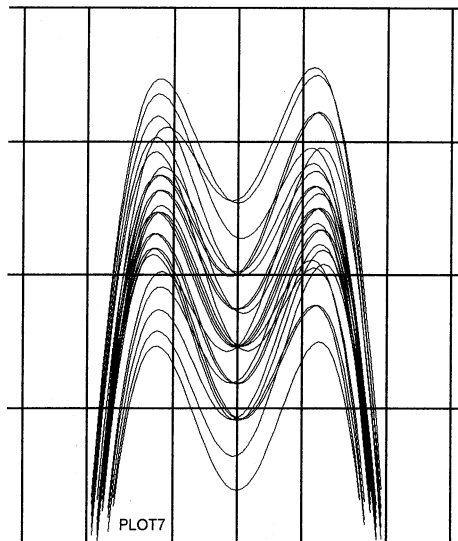

Figure 7 : effect of component tolerances of 2.5% (24 scenarios)
 Difference of two pairs of first-order sections, component values from Example 2a
 Axes: X: frequency (log scale 1-2-5), centre 1000Hz. Y: phase shift (3° intervals), centre 90°.

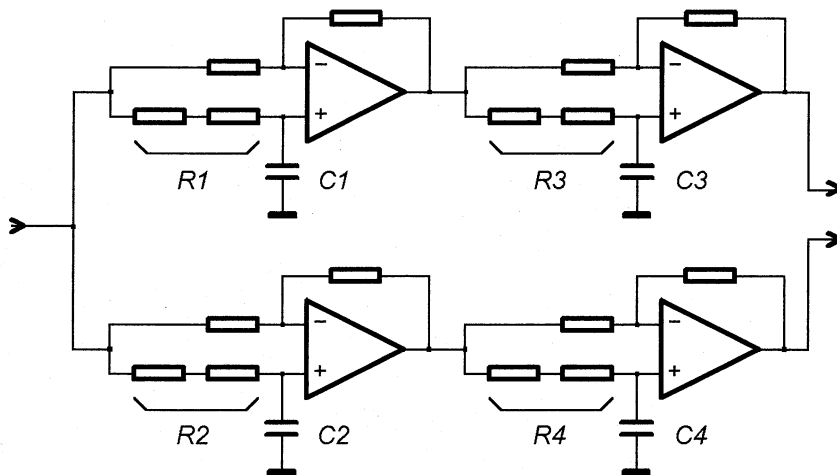

Figure 6: Circuit diagram of outphaser utilising difference of two pairs of first-order networks (see text)

$$f_1 = 142.9\text{Hz} \quad f_3 = 1715\text{Hz}$$

$$f_2 = 583.1\text{Hz} \quad f_4 = 6997\text{Hz}$$

If we want to alter the overall centre from 1000Hz we can scale these frequencies. However, we do not need to do that for this example. Using E24 resistors we can get close to these frequencies:

$$f_1 : 1.0\text{M}\Omega + 110\text{k}\Omega \text{ \& } 1\text{nF} \Rightarrow 143.4\text{Hz}$$

$$f_2 : 270\text{k}\Omega + 3.0\text{k}\Omega \text{ \& } 1\text{nF} \Rightarrow 583.0\text{Hz}$$

$$f_3 : 91\text{k}\Omega + 1.8\text{k}\Omega \text{ \& } 1\text{nF} \Rightarrow 1715\text{Hz}$$

$$f_4 : 22\text{k}\Omega + 750\Omega \text{ \& } 1\text{nF} \Rightarrow 6996\text{Hz}$$

Figure 5 shows the central portion of the phase response on an enlarged scale. The slight asymmetry of the curve is due to the errors caused by the resistor approximations. The response is only very slightly different from that predicted by Example 2.

Just to make it clear, Figure 6 shows a circuit diagram of the complete outphaser. The filters R_1/C_1 to R_4/C_4 use the values from the list above. The R s should be 1% metal film with a low temperature coefficient.

The C s should be polystyrene 1% parts. The unmarked resistors are all equal in value (say 100k Ω). They should be 1% metal film or, possibly 2% thick film resistor packs, for which the temperature tracking will probably be good. The op-amps should preferably be BiFet types with a low input current, or you will need to consider the effect of bias currents.

I have not shown any gain trimming, but this should be added in an appropriate place using a 20-turn cermet potentiometer. The filter inputs must be driven from a low impedance source.

Component Tolerances

What is apparent from the BASIC program is that the component tolerances are critical. Only slight deviations from the required values gives rise to noticeable increases in phase and amplitude error. To analyse the errors we will assume:

- i) that any error in the gain-setting resistors can be “tweaked” at a later stage in the circuit. This is true, but we still depend on the resistors “tracking” with temperature. Close tolerance, high stability parts will be beneficial.
- ii) that we can “transfer” the tolerance in the various R s to their respective C s. That is, using 1% R s and C s is the same as using exact R s and 2% C s. The analysis is easier because we now need only consider the C tolerance.

Although each component can drift independently it is likely that temperature will affect all parts similarly. Equally, it is unlikely that we will obtain four C s which combine to produce the worst possible effect. If circumstances *do* conspire against us then Figure 7 is representative. It shows 24 possible responses due to combinations of capacitor error. It is based on a capacitor tolerance of 2.5% (or 1% R , 1.5% C).

It shows that the original $\pm 1.5^\circ$ error has now become over $\pm 4.5^\circ$. Equation 2 tells us that *with no amplitude errors* this will increase the power in the unwanted sideband from -38dB to around -28dB which is a large reduction, but still adequate for some applications. Any error in the gain-setting resistors will make this even worse but, as noted earlier, we can trim the gain.

Difference of Four Pairs of 1st-Order Filters

The filter described above is probably perfectly adequate for many applications. However, in a multi-frequency radio, where much of the selectivity is provided by the outphaser, it must provide a very tight phase response over a large range (essentially zero to around 5 or 6kHz).

To get this accuracy is it necessary to use extra filter sections. The scheme was illustrated in an earlier article. (Figures 1 and 2 in Gibson, 1994). Simulating such a network by “trial and error” is tedious. I have recently re-run the analysis and come up with slightly better parameters⁹.

Example 4

The four pairs of filters are depicted in Figure 8. The centre frequency is 500Hz which means the four pairs are at 32.45Hz, 223.6Hz, 1118.0Hz and 7703Hz.

The frequencies of the individual first-order sections are found by multiplying and dividing by $\sqrt{\text{span}}$. The f_3/f_4 and f_2/f_6 pairs have a spread of 5.00. The overall spread between the f_1/f_2 and f_7/f_8 pairs is 237.4.

The response of a similar filter was plotted in the earlier article. The filter has a

⁹ There was a typing error in Gibson, 1994, Fig. 1, but that data is superseded by this article.

low ripple, as can be seen in Figure 9. The phase ripple is under $\pm\frac{1}{2}^\circ$, the error is within $\pm\frac{1}{2}^\circ$ from 41Hz to 6100Hz, and $\pm 1^\circ$ from 38Hz to 6460Hz. This is a very good performance, in terms of "bandwidth" and flatness, but will, of course, be made worse by component tolerances. I have not done an error analysis on the four-stage filter network, so I do not know how sensitive it might be to component values.

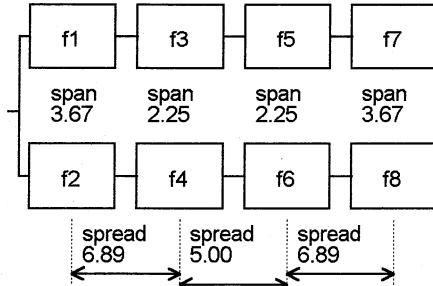

Figure 8 : difference of four pairs of first-order sections
Parameters similar to example in Gibson (1994)

Difference of Three Pairs of 1st-Order Filters

The trial and error approach is long-winded for four pairs of filters because there are too many variables. Example 4 could probably be tweaked to reduce the ripple, or to aid the choice of component values, but it is a long exercise. However, using three pairs of filters is a good compromise.

Example 5

We take a two pair filter with a span of 3.447 and a spread of 33. A third pair of filters are added at the centre frequency (in this case 1000Hz), with a span of 2.036. The result is shown in Figure 9. The ripple is an excellent $\pm 0.125^\circ$ and the 0.5° "bandwidth" is 256Hz to 3910Hz. These results are summarised in Table 1.

Wide bandwidth filters

Example 6

f1/f2	span 4.50	spread (to f3/4) 12
f3/f4	span 3.06	spread (to f5/f6) 9.0
f5/f6	span 3.06	spread (to f3/f4) 9.0
f7/f8	span 4.50	spread (to f5/f6) 12

If the schematic of Figure 8 has the above values then we have a filter which maintains a flat passband to $\pm 3^\circ$ over a bandwidth of 22Hz to 46200Hz (over 2000:1). This is illustrated in Figure 10 for a centre frequency of 1000Hz.

This is unprecedented, and far exceeds the performance of the old *polyphase* filters you sometimes still read about. A ripple of 3° is -32dB power attenuation. This could be improved on, in a precision application, but the example serves to demonstrate some of the possibilities of filter design.

It clearly shows that it is possible to use the same filter at a.f. and at r.f. This could be important because it simplifies the topol-

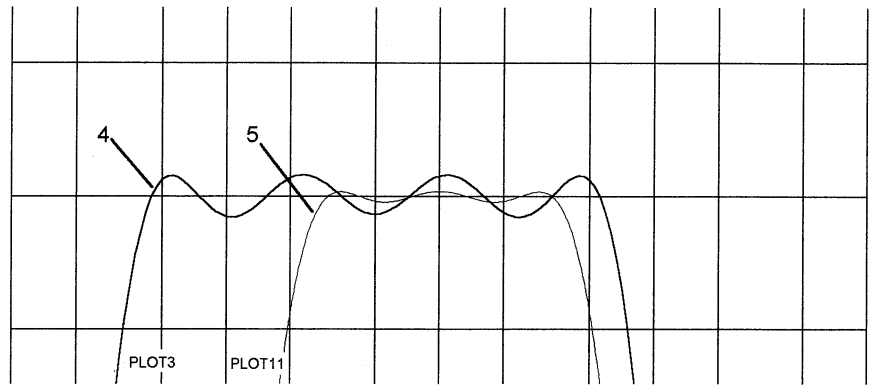

Figure 9 : Difference of three & four first-order sections
magnified central portion of response. Parameters from Examples 4 & 5
Axes: X: frequency (log scale 1-2-5), centre 1000Hz. Y: phase shift (3° intervals), centre 90° .

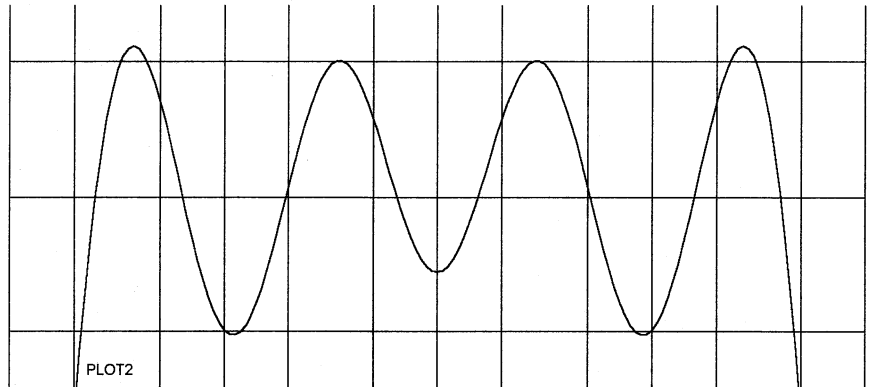

Figure 10 : Difference of four first-order sections
magnified central portion of response, parameters from Example 6.
Axes: X: frequency (log scale 1-2-5), centre 1000Hz. Y: phase shift (3° intervals), centre 90° .

Example	1 2 pairs	2 2 pairs	2a 2 pairs	3 2 pairs	4 4 pairs	5 3 pairs	6 4 pairs	G3 TDZ
Span	4.36	4.08		3.62	3.67 2.25	3.447 2.036	4.50 3.06	
Spread	14.0	12.0		9.00	6.89 5.00	33.0 --	12.0 9.0	
$\pm 3^\circ$ (Hz)	216 4620	254 3940	257 3890	350 2850		194 5160	22 46200	272 3310
$\pm 1^\circ$ (Hz)	240 4170	288 3470	292 3470	417 2400	39 6460	246 4240		309 2920
$\pm \frac{1}{2}^\circ$ (Hz)	245 4070	299 3450	302 3350	442 2260	41 6100	256 3910		320 2820
phase ripple	+2.66° -2.52°	+1.54° -1.55°	+1.4° +1.5° -1.6°	+0.29° -0.22°	+0.49° -0.47°	$\pm 0.13^\circ$	$\pm 3^\circ$	+1.2° +1.3° -0.4°

ogy of a multi-channel direct-conversion SSB radio. The same modulator-phaser-summer network could be used to up-convert audio to r.f. and to down-convert incoming r.f. to audio.

We might want to tweak the design to give a lower error in the a.f. band, but we can cope with a high error at r.f. For example $\pm 10^\circ$ is 1/60 (-18dB) which is adequate for the attenuation of the unwanted transmission sideband. (We are not subject to modulation-type or channel restrictions in the induction radio band).

Using integrated filters

In the preview of this article (*Journal 21*, inside front cover) I said that one example of outphaser design would make use of a filter IC. There are two types of integrated circuit filter; the switched-capacitor filter and the continuous time filter. I had earlier discounted switched capacitor filters because they have a restricted range of clock frequencies. I could not tune them to get the precise centre frequencies that I wanted. And there is the question of clock noise too. I was intending to use one of the continuous-time filters from *Maxim*. These are state-

variable filters using conventional op-amps and on-chip Rs and Cs which are close-matched. When I looked into this closer, I found that they were not matched any closer than I could achieve by using 1% components. I have not ruled out using a c.t. filter chip, but it seems that op-amps and 1% components will do just as well.

Using discrete components allows us to tighten up the tolerances if we particularly need to. A 1% 50ppm/°C resistor costs around £0.03. A 1% -100ppm/°C capacitor is around £0.35. The gain-setting resistors do not benefit from a tighter tolerance because we can trim the gain, but we could consider using 0.1% 10ppm/°C resistors for the RC filters. These cost around £0.80 each but, since they are available in E96 values, we will probably only need one per filter section. The total cost of the passive components for the filter of Figure 6 is £1.88 for the "normal" version and £4.88 for the "tight tolerance" version.

Using the Filter in a Receiver

The schematics discussed so far have implicitly given the configuration for a transmitter. The same module is used in a receiver but the quadrature signals from the demodulator drive the inputs to the two filter chains, which are summed (or differenced) at the output to recover one of the sidebands.

Summary

We have shown that an outphaser of adequate performance can be built using four first-order filters using the straightforward circuit of Figure 6.

Other circuit configurations are possible, but these tend to use second order filters, which are more difficult to analyse. Even if the analysis is already done for us, there are practical problems with second-order filters; e.g. component tolerances which cause a gain error cannot be trimmed out as they can for a first-order filter.

In many applications this is only of academic interest. An exact phase shift is not important because there is still adequate attenuation of the unwanted sideband; and the circuit values are already calculated.

However, in crucial applications the use of tight-tolerance components means that a high degree of attenuation can be guaranteed in the unwanted sideband. We can easily increase the number of filter sections if we want to increase the "bandwidth" or reduce the ripple.

The practical example given in the text should enable designers to interpret some of the other examples which were described only in terms of *span* and *spread*.

References

- Gibson, David (1992), *SSB Modulation Review*, JCREG 8, pp12-16, June 1992
 Gibson, David (1994), *Designing an SSB Transmitter Module*, JCREG 15, pp15-18, Dec. 94
 Hey, John (1995), *Journal 22 reference*. JCREG 22, pp12-16, Dec. 1995
 Walters, L.C. (1986), *Improved Hilbert Transformer for S.S.B. Speech*, Electronics & Wireless World, 93(1602), pp20-24, April 1986

Copyright © 1995 David Gibson

Appendix – G3TDZ Phaser from John Hey

John Hey's phaser, as used in his new Cave Radio design (Hey, 1995), is based on the difference between one pair of second-order sections. The theoretical gain and phase response are in Figure 11. The phase ripple is around 1.5°, the ±3° points at 270Hz and 3300Hz. The data is in Table 1 in the main text. The filter is similar in performance to my Example 2a.

Component tolerances will increase the gain error in the G3TDZ circuit. It is not possible to separate the control of gain and phase, and the error cannot be trimmed. Fortunately it is very low to begin with, and we can tolerate a reasonably large error. In the circuits I have discussed, the gain error can be trimmed if we need to.

In Figure 11 the gain is shown as the ratio of the gain from one of the filter channels to the other. This is a maximum of 1.0098 at around 280Hz. The two channels can therefore be described as having a gain error of ±0.0049 relative to each other. Setting $\alpha = 0.0049$ and $\phi = 1.5^\circ$ in (2) suggesting -31dB[W]. John got -26dB in practice.

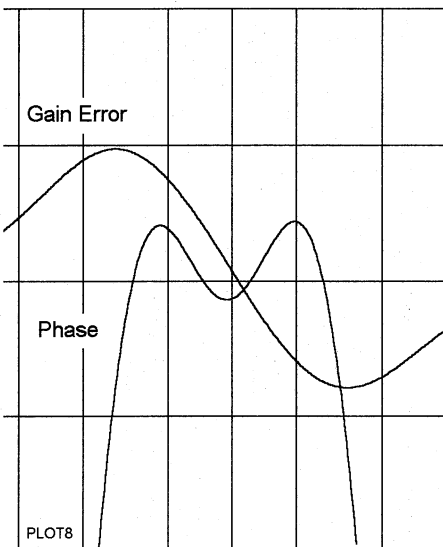

Figure 11 : John Hey's Phaser.
 Difference of one pair of second-order sections
 Axes: X: frequency (log scale 1-2-5), centre 1000Hz.
 Y: phase shift (3° intervals), centre 90°. gain error (0.01 intervals, centre 1).

A Slave for RALF

continued from page 10

I will be providing kits of parts for this design. You can order the basic slave unit, with or without the RALF part A additions. The prices are listed below, and include postage / packing world-wide. Please make cheques payable to A.D. Gibson and send to 12 Well House Drive, LEEDS, LS8 4BX.

The other items (the part B additions – magnet, batteries etc.) are also available, but you can obtain these, yourself, as you need them, from *Maplin Electronics*¹⁰.

As with the previous design, I offer this caveat. If any components are faulty then they will be replaced, but I offer no other guarantees. The design is a development prototype and the components – some of which may be hard to obtain – are offered simply as a favour to constructors. What you do with them is entirely up to you!

Item	1 off	3 off
Basic slave unit	11.00	8.33
Slave with RALF additions, part A	14.00	11.00
RALF additions, part B.		
(reed, d.i.l. switch, batts, magnet)	6.00	4.50
(* only 1 magnet supplied)		(*)
Flashgun Slave pamphlet	1.00	---
Printed circuit board only	3.50	3.00

Electronic components are cheaper when bought in bulk, but this is something I cannot afford to do, having already invested in the pcb manufacture¹¹. If I could guarantee to sell 100 kits, then the price would come down to around £8.00 for the RALF slave. This is a saving of £24 if you want eight slaves. However, feedback from Mike Bedford's article in *Journal 21* suggests that maybe there are not enough interested people to make this worthwhile. You can, of course, obtain your own components – I will supply the pcb on its own.

References

- Gibson, David (1992), *A High-Performance Flashgun Slave*, JCREG 10, pp7-12, Dec. 92
 Gibson, David (1994), *A High-Performance Flashgun Slave*, Published CREG
 Bedford, Mike (1995a), *The RALF Concept*, JCREG 21, pp20-22, Sept. 95
 Bedford, Mike (1995b), *The "Standard" Caving Flash Connector*, JCREG 22, p24 Dec. 95

Copyright © David Gibson, 1995.

The intention, in publishing this article, is to present a circuit for private constructors to build and use. It is not the intention to allow commercial use of this design without the prior written permission of the author.

¹⁰ Telephone 01702 554161. *Maplin* levy a carriage charge of £1.50.

¹¹ A grant from the BCRA's Jeff Jefferson Research Fund has been applied for, to cover the cost of putting together a set of prototypes and testing the RALF concept underground. At the time of writing the success, or otherwise, of this application is not known.